

Ontario Fire Code

SECTION 5.13 *DIP TANKS*

Illustrated Commentary



*Office of the
Ontario
Fire Marshal*

5.13.1. Location

5.13.1.1. Dip tank operations involving **flammable** or **combustible liquids** where the quantity exceeds 45 L or the liquid surface area exceeds 0.42 m² shall be conducted in a room designed for that purpose and separated from the remainder of the **building** by a **fire separation** having a 2-hr **fire-resistance rating**.

Dip tank operations involving the use of flammable or combustible liquids produce flammable vapours that when mixed with air may be easily ignited.

To prevent the spread of fire this Article requires a properly designed room for a dip tank operation that involves a capacity of over 45 L or a liquid surface area over 0.42 m².

The intent is to reduce the risk of a fire in the dipping or coating area spreading to other parts of the building and endangering building occupants.

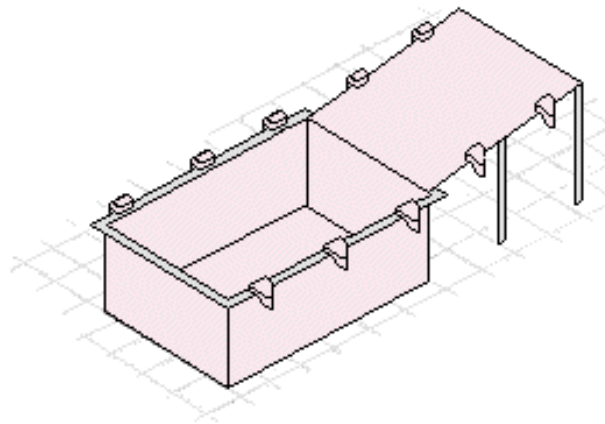

Building means any structure used or intended for supporting or sheltering any use or **occupancy**.

Combustible liquid means any liquid having a **flash point** at or above 37.8°C and below 93.3°C.

Flammable liquid means a liquid having a **flash point** below 37.8°C and having a **vapour pressure** not more than 275.8 kPa (absolute) at 37.8°C as determined by ASTM D 323, "Vapor Pressure of Petroleum Products (Reid Method)".

Fire-resistance rating means the time in hours or fraction thereof that a material or assembly of materials will withstand the passage of flame and the transmission of heat when exposed to fire under specified conditions of **test** and performance criteria, or as determined by extension or interpretation of information derived therefrom as prescribed in the **Building Code**

Fire separation means a construction assembly that acts as a barrier against the spread of fire and may or may not have a **fire-resistance rating** or a **fire-protection rating**.

5.13.1. Location

5.13.1.2. Dip tanks shall not be located in **cellars** or **basements**.

This Article prohibits the location of dip tanks, regardless of their size, in cellars or basements since flammable liquid vapours are heavier than air.

The intent is to:

- reduce the accumulation of flammable or combustible vapours to ignitable concentrations in low areas of a building that would create a fire or explosion hazard and endanger building occupants.
- reduce delays and impairments to emergency response operations because of difficult access to basements that could result in the spread of fire or explosion and cause harm to building occupants and emergency responders.

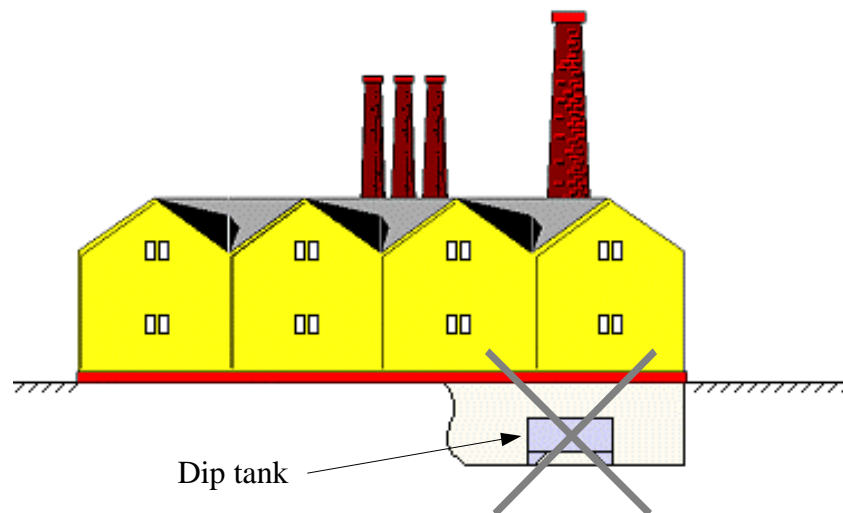

Cellar means a **basement** that is more than 50 per cent below **grade**.

Basement means a **storey** or **storeys** of a **building** located below the **first storey**.

5.13.2. Construction

Floors

- 5.13.2.1. The floor of any room where dip tanks are located shall be made liquid tight with material that is impervious to the liquid in the tank, have permanent curbs and be drained to a place of safe discharge.

The requirements in this Article are intended to reduce the risk of an overflow of the tank contents spreading the spill/fire to other parts of the building and endangering building occupants, or causing damage to the environment.

To control a spill, the floor must be impervious to the liquid and drained to a place of safe discharge.

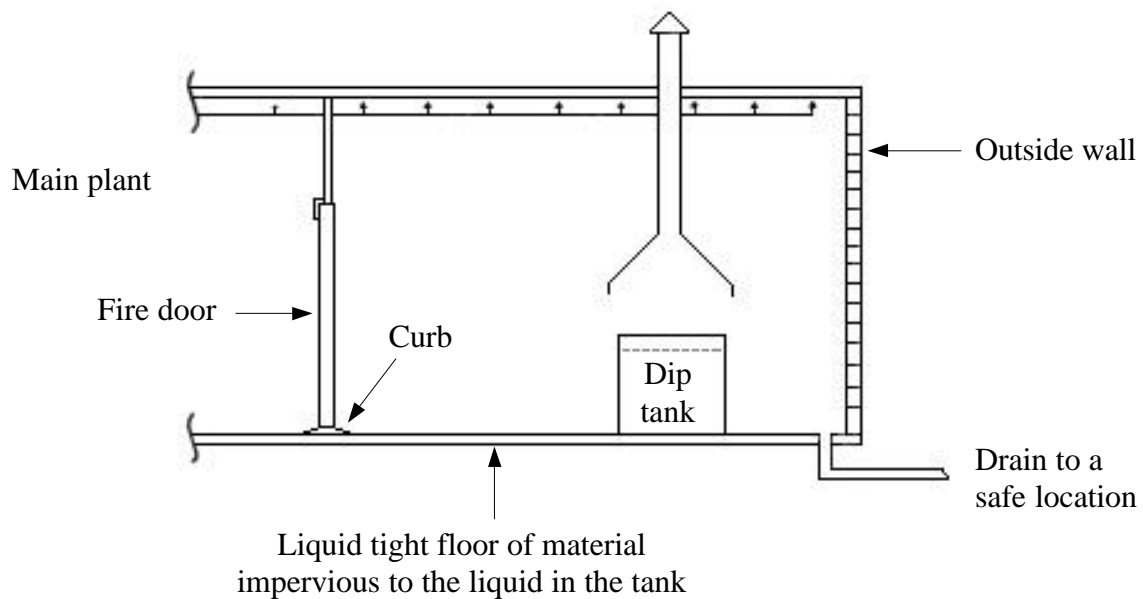

5.13.2. Construction

Materials

- 5.13.2.2.(1) Dip tanks and drain boards shall be constructed of noncombustible material with steel, reinforced concrete or masonry supports.
- (2) Drain boards shall be arranged to drain back to the dip tank.

The materials specified in Sentence (1) are necessary to limit the combustible content [noncombustibility] and to avoid collapse of the dip tank and drain board under fire conditions.

Sentence (2) ensures that liquid dripping from dipped material will drain back to the dip tank and not on to the floor.

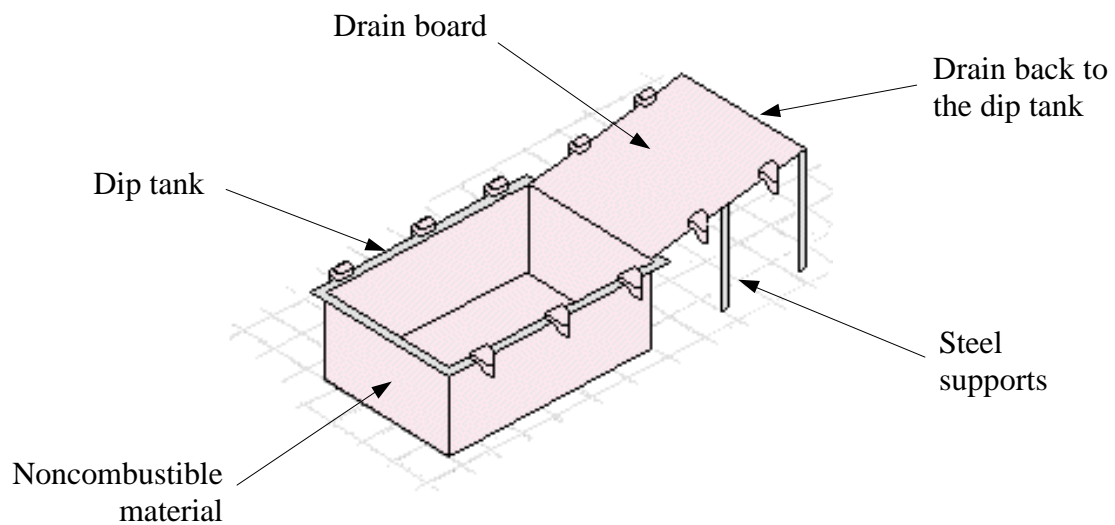

5.13.2. Construction

Height above floor

5.13.2.3. The top of a dip tank shall not be less than 150 mm above the floor of the room in which it is located.

The distance indicated by this Article is intended to reduce the risk of water or other material on the floor adjacent to the dip tanks from entering into the tank and causing the overflow of the tank contents that could be ignited and endanger building occupants.

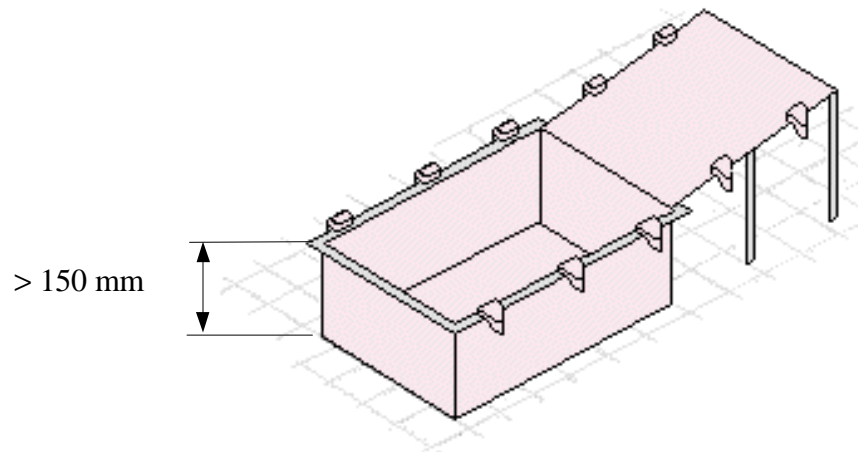

5.13.2. Construction

Covers

5.13.2.4. Dip tank covers as required in Articles 5.13.6.2 and 5.13.6.3. shall be of noncombustible materials.

5.13.2.5. Dip tank covers shall overlap the sides of the tank by 25 mm and shall have a recess or flange extending down around the tank.

5.13.2.6. Dip tank covers shall be maintained in good operating condition.

The simplest device for confining and extinguishing a fire in a process tank is a self-closing cover, which cuts off the fire's oxygen supply, thus extinguishing the fire.

To perform this function properly, the cover must be made of noncombustible material to stop the fire from penetrating it, and also be large enough to cover the entire surface of the tank. The recessed or flanged edges on the cover ensure that the lid acts as an effective barrier to the spread of fire and limits the quantity of oxygen from entering the enclosed space.

It is equally important that the covers are maintained in good operating condition so that they will close quickly and tightly in the event of a fire.

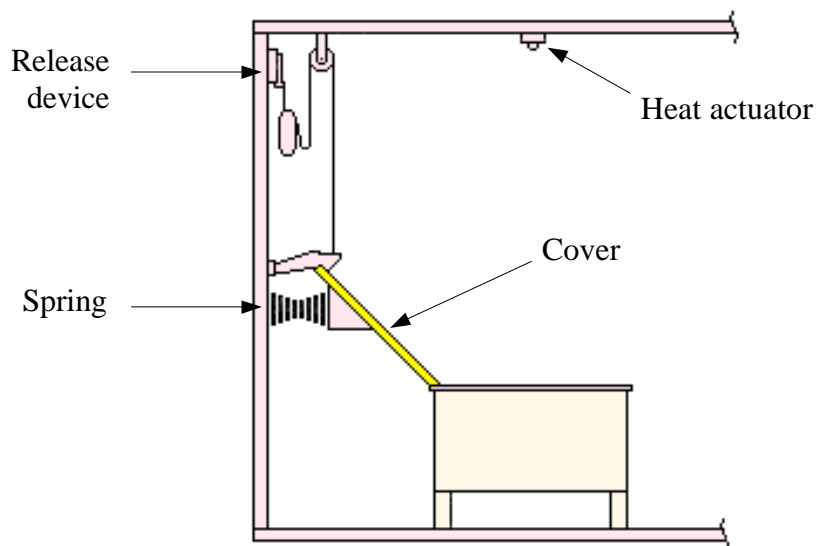

5.13.3. Overflow and Drain Pipes

Liquid levels

- 5.13.3.1. The liquid level in a dip tank shall be kept not less than 150 mm below the top of the tank.

The restriction on the level of the liquid in a dip tank applies to all dip tanks and is intended to prevent an overflow of the tank contents that could be ignited.

Possible causes for overflow:

- Normal dipping or filling operations,
- Wave action from dropping an object in the tank, or
- Water used for fire fighting purposes [or other extinguishing agent] applied to a fire in the dip tank,

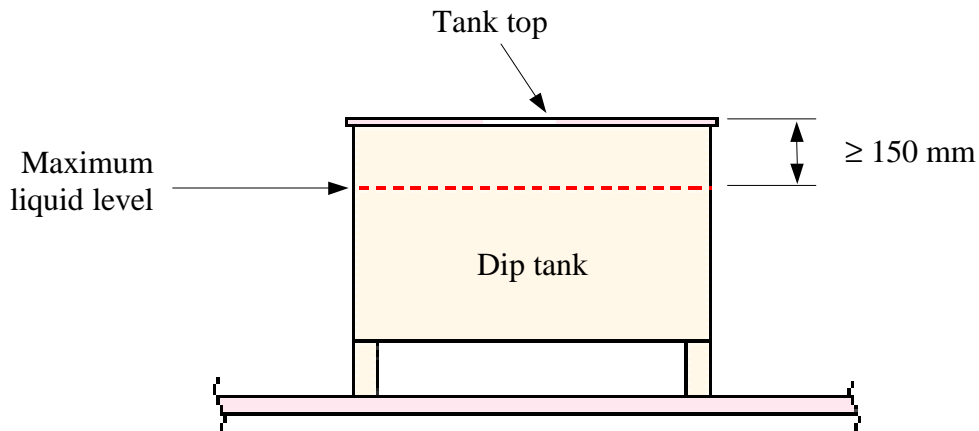

5.13.3. Overflow and Drain Pipes

Overflow pipes

- 5.13.3.2. Dip tanks having a capacity in excess of 550 L or having a liquid surface area in excess of 1 m² shall be equipped with a properly trapped overflow pipe that leads to a safe location outside the **building** or to a closed, vented salvage tank conforming to Subsection 5.13.4.

The purpose of this Article is to ensure that large tanks are provided with features that will prevent accidental overflow.

The continuing intent is to provide a safe location for any overflow resulting from overfilling and water used for fire fighting.

By requiring a properly trapped overflow pipe, the intent is to prevent flame propagation from a burning overflow of flammable or combustible liquids traveling beyond the trap reaching the salvage tank or flashback from the storage tank into the dip tank.

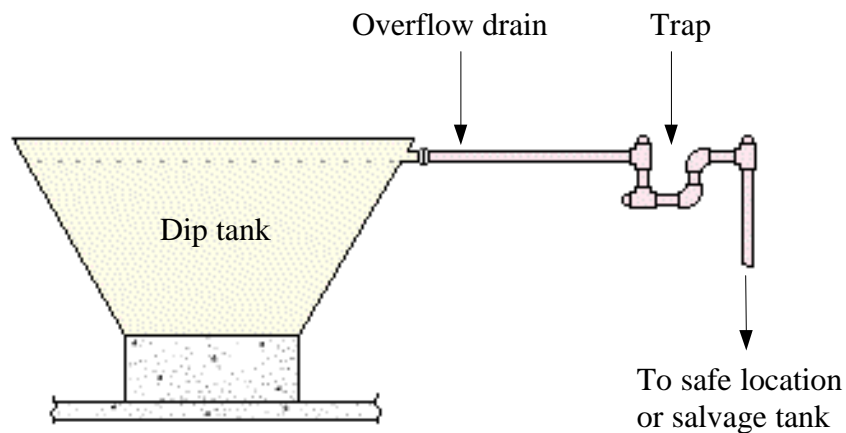

Building means any structure used or intended for supporting or sheltering any use or **occupancy**.

5.13.3. Overflow and Drain Pipes

Overflow pipes

5.13.3.3. The centre line of the overflow connection to a dip tank shall be 150 mm below the top of the tank.

This Article indicates the location of the overflow connection to a dip tank as a measure to prevent the liquid in the tank to raise to a level higher than the level allowed by Article 5.13.3.2.

The continuing intent is to reduce the possibility of an overflow from:

- Normal dipping or filling operations,
- Wave action from dropping an object in the tank, causing the overflow of the tank contents that could be ignited and endanger building occupants, or
- Water used for fire fighting purposes [or other extinguishing agent] applied to a fire in the dip tank,

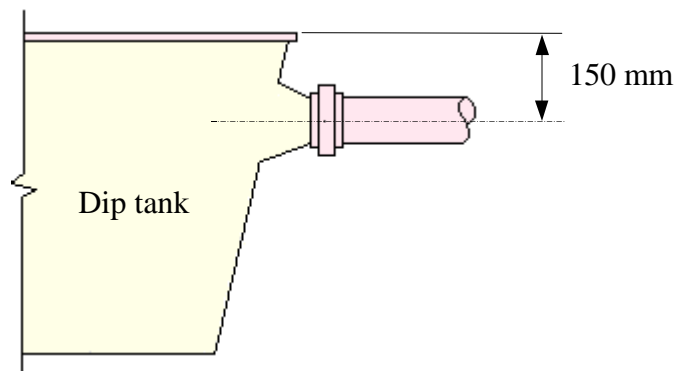

5.13.3. Overflow and Drain Pipes

Overflow pipes

5.13.3.4. Overflow pipe sizes for dip tanks shall conform to table 5.13.3.A.

TABLE 5.13.3.A.
Forming Part of Article 5.13.3.4.

Size of Tank, L	Overflow Pipe Size Required, Mm
0 – 46	50
47 – 160	65
161 – 350	75
351 – 700	100
701 – 1025	125
1026 – 1500	150
1501 and over	200

The concept is that the overflow pipe must be able to displace the raised volume in the dip tank at a maximum rate of discharge. If the drain pipe is too small, the overflow liquid could not be drained off safely and quickly, but would overflow from the top of the tank.

Sizing the drain pipe for maximum anticipated overflow will allow for the discharge of liquid to drain to a safe location and thereby prevent the liquid from spilling into the room. Also, in a fire situation, if there is an overflow due to fire fighting suppression water or sprinkler discharge entering the dip tank, the overflow pipe will be capable of transferring the liquid to a safe area or to the salvage tank.

5.13.3. Overflow and Drain Pipes

Overflow pipes

5.13.3.5. Overflow pipe shall be connected to dip tanks by a flared outlet.

The intent is to avoid build-up of deposits that could reduce the capacity of the pipe and result in the overflow of the tank contents that could be ignited and endanger building occupants.

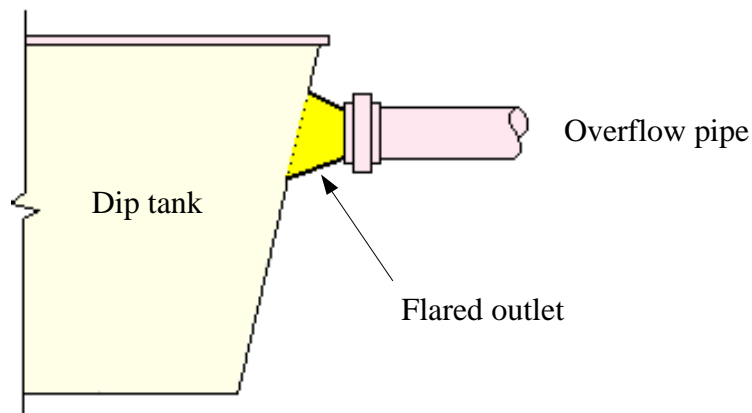

5.13.3. Overflow and Drain Pipes

Piping connections

- 5.13.3.6. Piping connections for drains and overflow lines shall be designed so as to allow for easy access to their interiors for cleaning purposes.

One of the measures of hazard reduction is proper maintenance and periodic inspections.

Careful evaluation of the process is necessary when designing the piping connections for drains and the overflow lines so that their interiors be accessed easily for cleaning purposes.

Given the size of the tanks to which this Article applies, this is a very important requirement to help avoid build-up of deposits that could reduce the capacity of the pipe and result in the overflow of the tank contents that could be ignited and endanger building occupants.

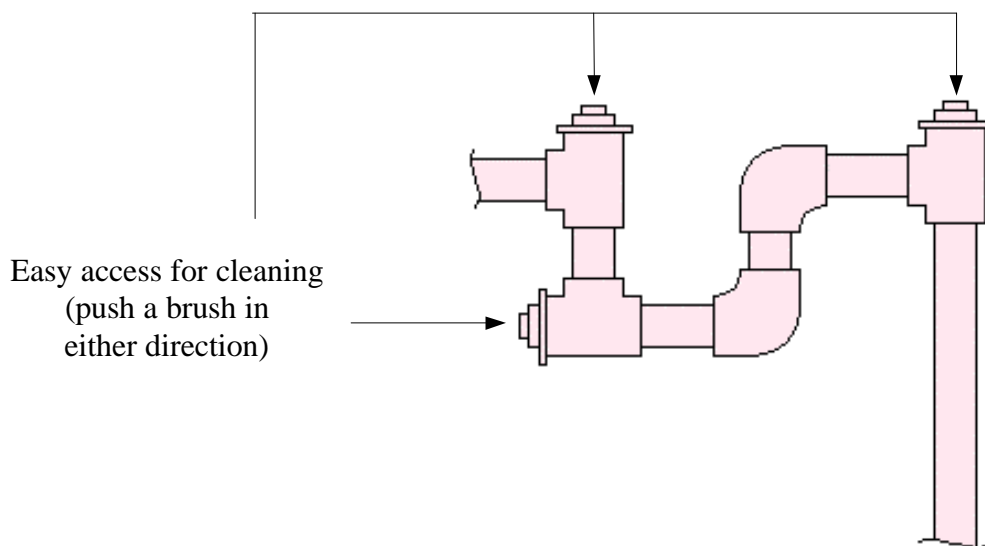

5.13.3. Overflow and Drain Pipes

Bottom drains

- 5.13.3.7. Dip tanks of over 2300 L liquid capacity shall be equipped with bottom drains capable of being operated both automatically and manually to drain the tank quickly in the event of fire.

Bottom drains are required for large tanks since the consequences of a fire would be extremely serious.

The bottom drain must be capable of being operated automatically and manually with the result of emptying the tank as quickly as possible in the event of fire.

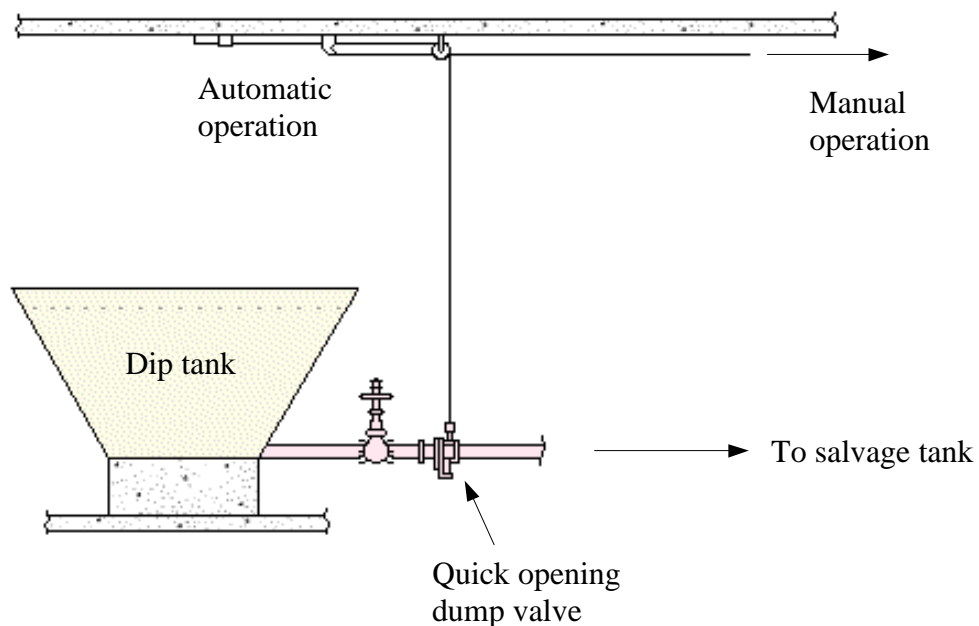

5.13.3. Overflow and Drain Pipes

Bottom drains

5.13.3.8. Bottom drains from dip tanks shall be trapped and shall discharge to a closed, vented salvage tank.

The objective of this Article is the safe discharge of flammable and combustible liquids from dip tanks that are provided with bottom drains.

It requires the drains to discharge to a closed, vented salvage tank, but does not put restrictions on the location of the tank allowing, for example, the use of an existing salvage tank located in the building or outside.

Traps on bottom drains ensure that a fire involving liquid in either the dip tank or the salvage tank will not spread to the other tank because the flame is stopped at the trap.

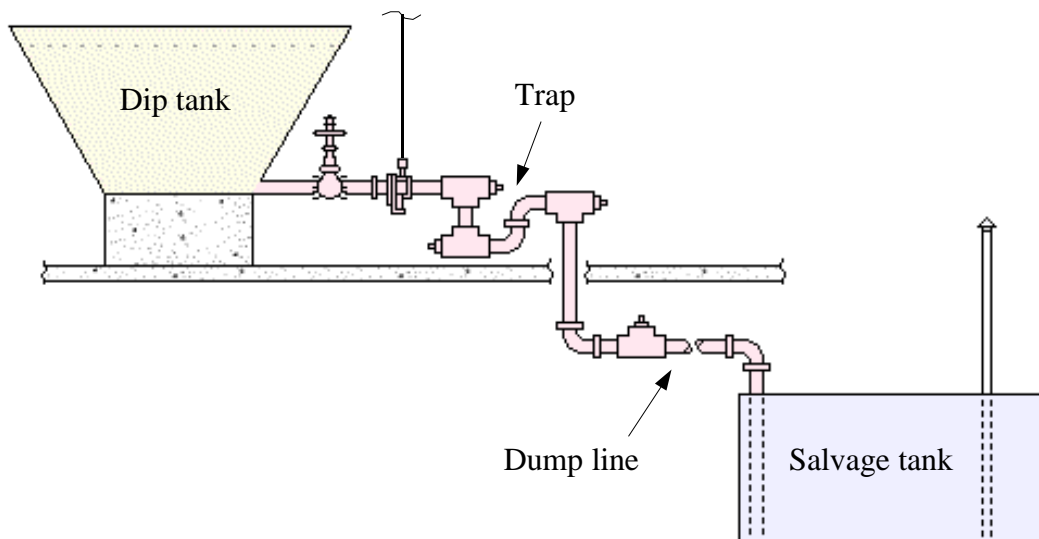

5.13.3. Overflow and Drain Pipes

Bottom drains

5.13.3.9. Bottom drain sizes for dip tanks shall conform to Table 5.13.3.B.

TABLE 5.13.3.B.
Forming Part of Article 5.13.3.9.

Capacity of Dip Tank, L	Diameter of Bottom Drain Pipe, mm
2300 – 3425	75
3426 – 4550	100
4551 – 11500	125
11501 – 18250	150
15251 and over	200

Sizing the bottom drain based on the dip tank size (larger tanks require larger drains) allows the discharged liquid to drain quickly from the dip tank to the salvage tank in the event of a fire in the dip tank. This will reduce the volume of liquid that can be consumed by a fire.

5.13.3. Overflow and Drain Pipes

Manual operation of bottom drains

5.13.3.10. Manual operation of bottom drains shall be from an accessible location not affected by a fire in or around the dip tank.

It is important that devices provided for manual release of the bottom drain are accessible in the event of a fire in the vicinity of a dip tank.

An accessible location for the bottom drain manual release device will help:

- avoid injuries to the person operating the valve during a fire.
- avoid delays in manually opening the bottom drain due to the failure [non-operation] of the automatic quick release drainage mechanism.

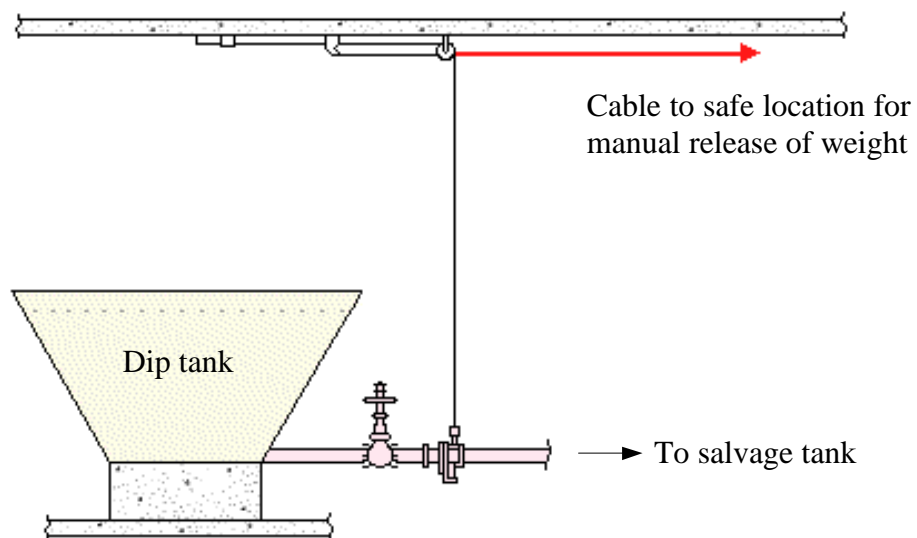

5.13.3. Overflow and Drain Pipes

Automatic pumps

5.13.3.11. Where gravity flow is not practical, automatic pumps shall be installed on drain lines from dip tanks.

The intent of this Article is to make sure that where gravity flow is not possible (for example when the salvage tank and the dip tank are on the same floor) then automatic pumps must be provided to ensure that the dip tank can be drained rapidly.

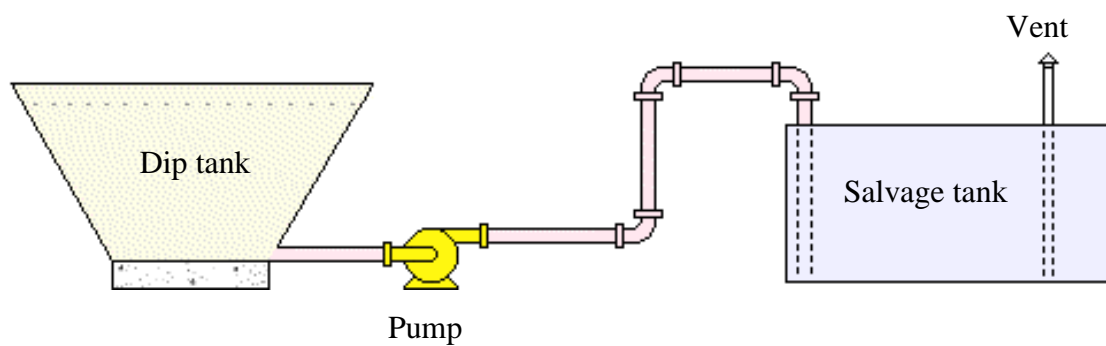

5.13.3. Overflow and Drain Pipes

Automatic pumps

5.13.3.12. Where salvage tanks are used, pumping arrangements shall be provided for the transfer of their contents for disposal.

The Article applies to salvage tanks containing more than 2300 L of flammable or combustible liquids. Requiring pumping arrangements to be provided for salvage tanks will ensure that the salvage tanks can be promptly emptied.

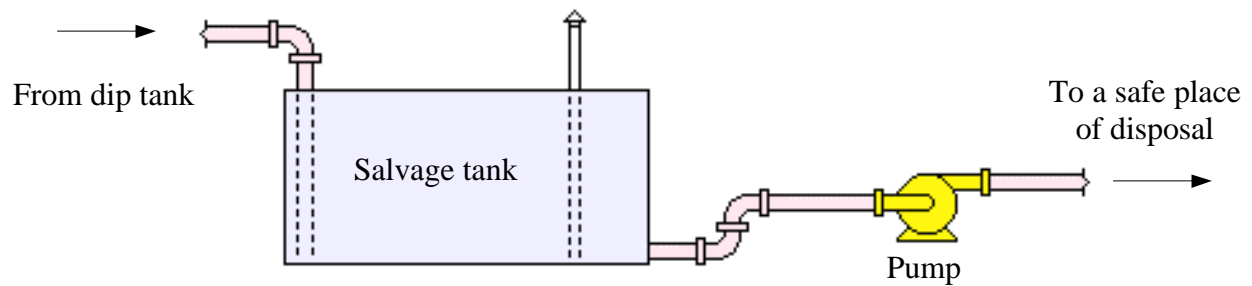

5.13.4. Salvage Tanks

Use

5.13.4.1. Salvage tanks shall be used only for temporary storage purposes.

Capacity

5.13.4.2. The capacity of a salvage tank shall be 20 per cent greater than the capacity of the dip tank or tanks to which it is connected.

Salvage tanks are not to be used for storage. They have to be emptied to ensure that the salvage tank is available in the event of the need to divert dip tank contents to the salvage tank in a fire situation.

The salvage tank must be 20 per cent larger than the capacity of the dip tank in order to accommodate the entire volume of the dip tank, plus minor spills and fire suppression water.

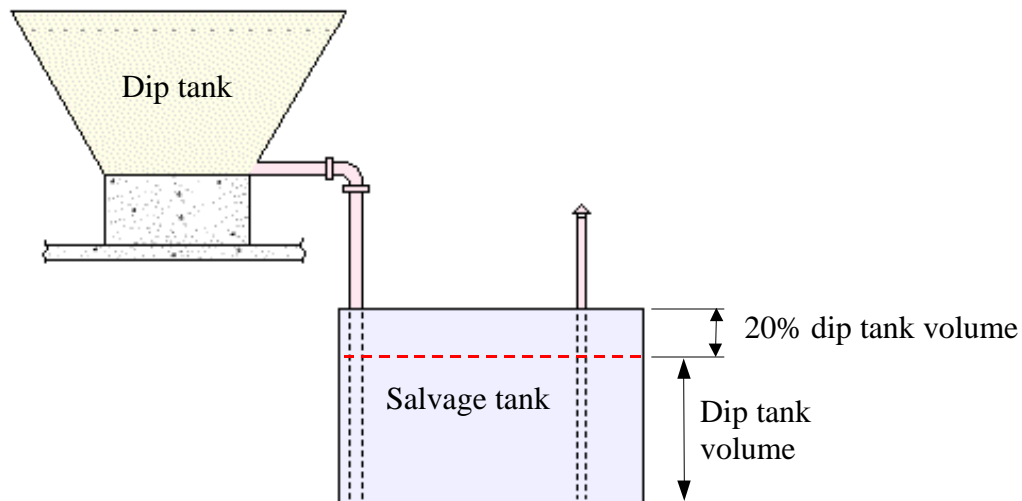

5.13.4. Salvage Tanks

Location

- 5.13.4.3. Salvage tanks shall be located underground in the yard or inside a **building** in an enclosure separated from the remainder of the building by a **fire separation** having a 2-hr **fire-resistance rating**.

By placing the salvage tank underground it reduces the risk of fire spreading from the salvage tank to nearby buildings or storage areas.

If the salvage tank is located in the building, a fire separation is necessary to isolate the tank from the rest of the building to prevent the spread of fire to other parts of the building.

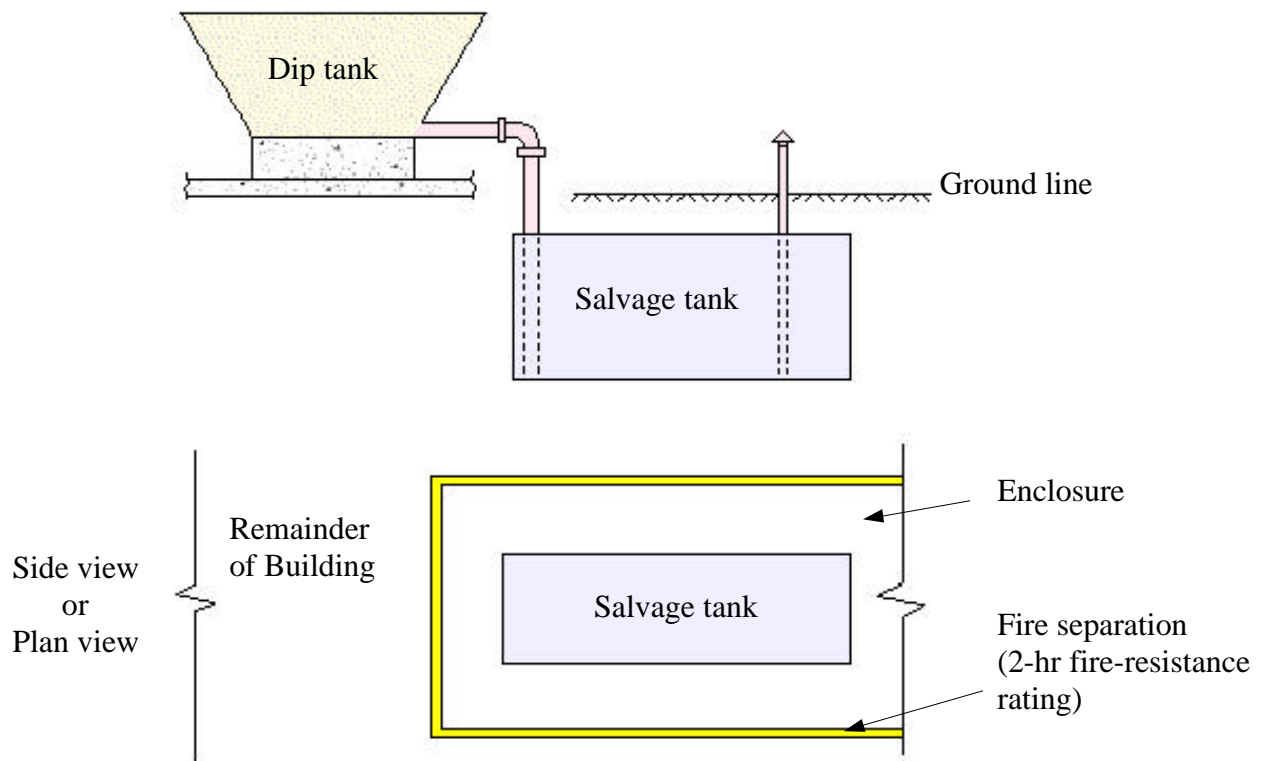

Building means any structure used or intended for supporting or sheltering any use or **occupancy**.

Fire resistance rating means the time in hours or fraction thereof that a material or assembly of materials will withstand the passage of flame and the transmission of heat when exposed to fire under specified conditions of **test** and performance criteria, or as determined by extension or interpretation of information derived therefrom as prescribed in the **Building Code**

Fire separation means a construction assembly that acts as a barrier against the spread of fire and may or may not have a **fire-resistance rating** or a **fire-protection rating**.

5.13.5. Control of Fire Hazards

Ventilation

- 5.13.5.1. Ventilation shall be provided to confine all flammable vapour concentrations exceeding 25 per cent of the **lower explosive limit** to within 600 mm of the dip tank, drain board and freshly coated work.

Ventilation is necessary to confine the flammable range of vapours to the smallest practical space possible. This requirement extends to the dip tank, drain board and freshly coated work because these areas are likely to produce vapours.

A properly designed and maintained ventilation system will not allow the vapour area to extend beyond 600 mm from the vapour source.

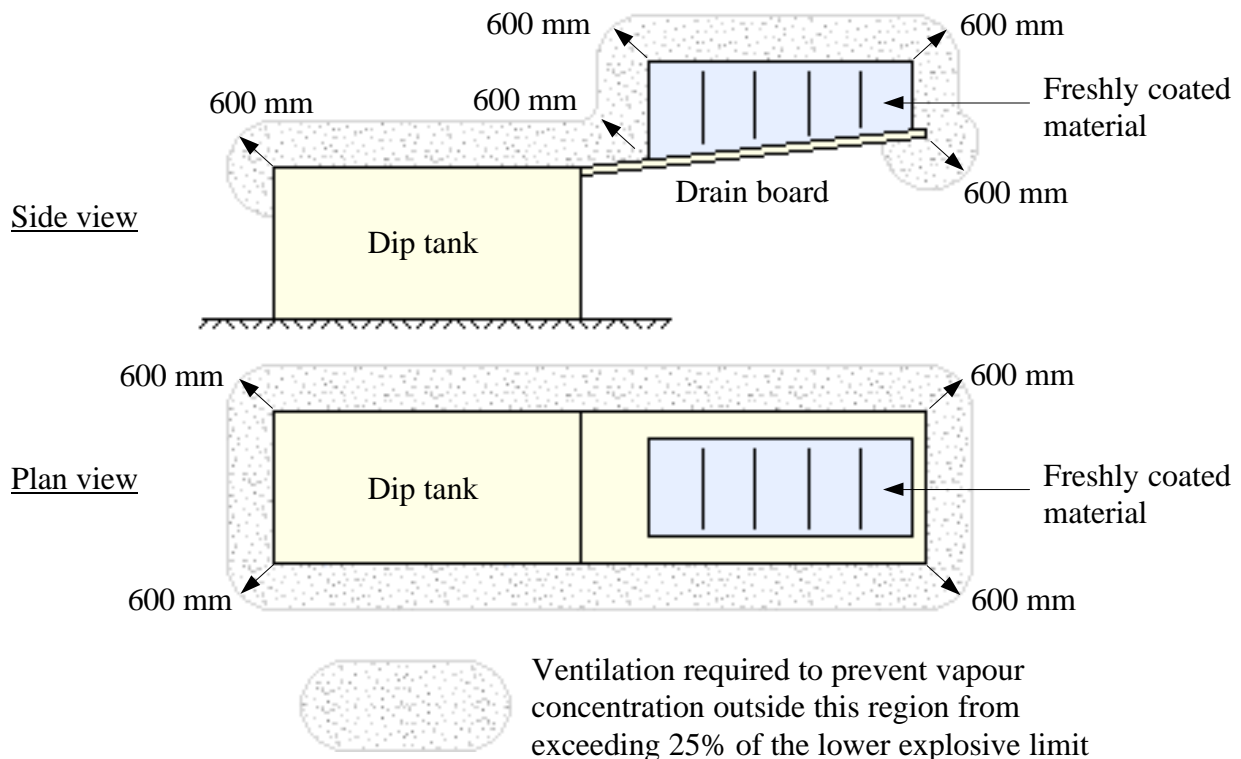

Lower explosive limit means the minimum concentration of vapour in air at which the propagation of flame occurs on contact with a source of ignition.

5.13.5. Control of Fire Hazards

Interlocks

5.13.5.2. Ventilating systems shall be arranged so that the failure of any ventilation fan as sensed by air flow will automatically stop the dipping conveyor systems and sound an alarm.

Failure of any ventilation fan would permit flammable vapours to accumulate to ignitable concentrations. The requirement is to automatically stop the process and sound an alarm when the air flow senses a fan failure so that corrective measures can be taken immediately.

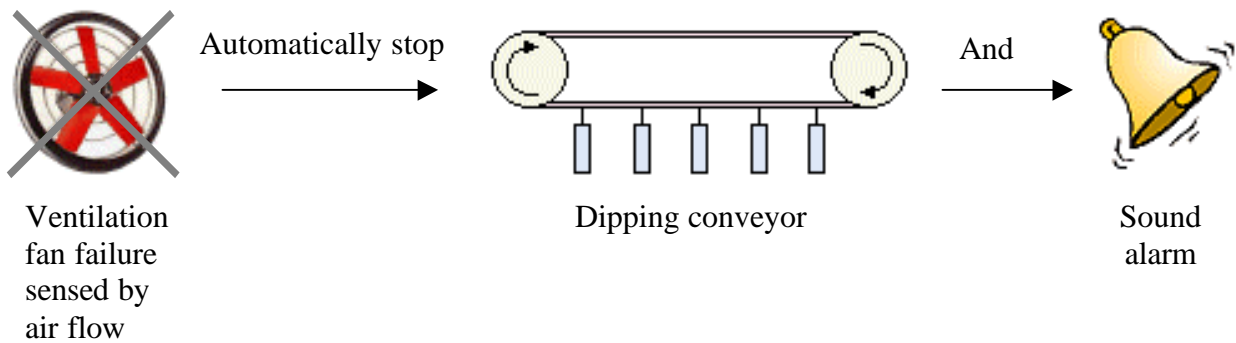

5.13.5. Control of Fire Hazards

Interlocks

5.13.5.3. The heating system used in drying operations shall be interlocked so that it cannot be started until the associated ventilation system is in operation.

The requirement in this Article is to have the ventilation system in operation before the heating system can be started in order to remove flammable vapours prior to the heating system being turned on.

By interlocking the two systems, the ventilation system will be in operation first and the heating system second.

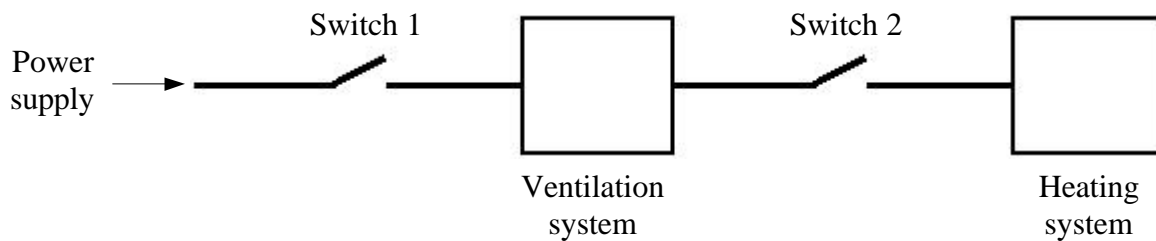

A simple illustration of an interlock where switch 1 must be engaged to operate the ventilation system before switch 2 can provide power to the heating system.

5.13.5. Control of Fire Hazards

Conveyor systems

5.13.5.4. Conveyor systems utilized in conjunction with dip tanks shall be designed to stop automatically with the actuation of an automatic fixed extinguishing system or a manual fire alarm.

The intent is to reduce the risk of a fire in the dipping or coating area spreading to other parts of the building through burning objects on the moving conveyor.

Conveyor systems used in dipping processes involving flammable or combustible liquids must be interlocked so that they will stop automatically in the event of fire, whether the fire is signaled by the actuation of the automatic extinguishing system or by the manual fire alarm.

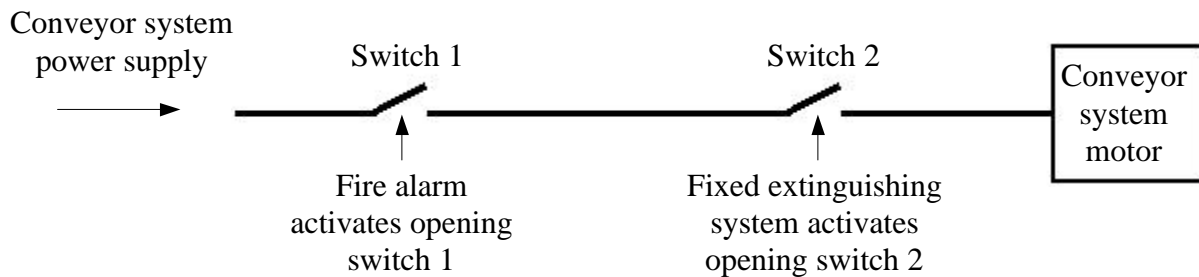

A simple illustration of an interlock where switches 1 and 2 are normally engaged to operate the conveyor system. Upon actuation of the fixed extinguishing system or manual fire alarm, the switch opens shutting off the conveyor system.

5.13.5. Control of Fire Hazards

Purging interlocks

5.13.5.5. Where there is a possible source of ignition in a drying operation, interlocks shall be installed to provide for purging before the heating system can be started and for automatic shutdown if the ventilation system should fail.

In order to reduce and control the fire hazards in the drying operations where there are possible sources of ignition, interlocks are required to make sure the drying enclosure is purged before the heating system can be started, and to automatically shutdown if the ventilation system fails.

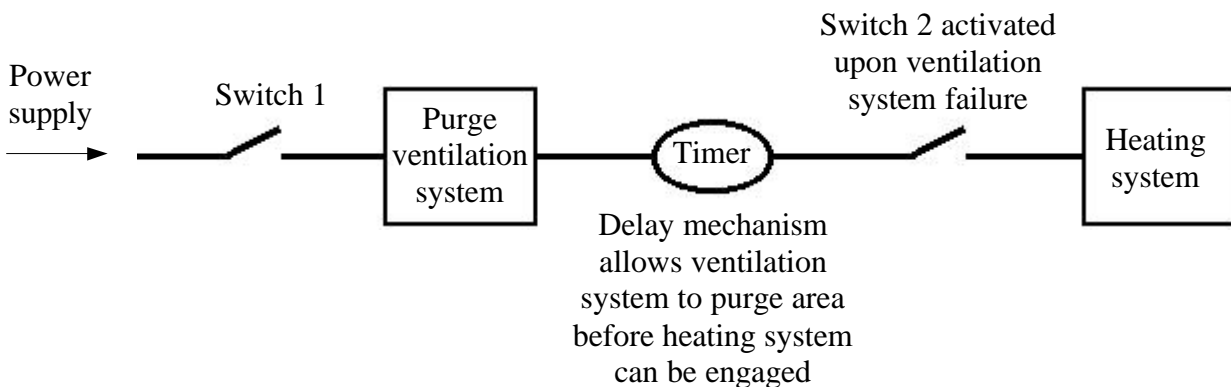

A simple illustration of purging interlocks.

5.13.5. Control of Fire Hazards

Electrical installations

- 5.13.5.6. Where **flammable** and **combustible liquids** contained in dip tanks are heated or have a **flash point** below 43°C, the electrical installation shall conform to the **Electrical Safety Code** made under the **Power Corporation Act**.

When the process requires that the flammable and/or combustible liquids contained in the dip tank are artificially heated, or if they have a flash point below 43°C, special attention must be directed to the electrical equipment due to the increased risk of fire or explosion.

Electrical equipment and wiring can generate ignition sources capable of igniting flammable vapours produced by dip tank operations. In order to control this hazard the electrical installation must conform to the requirements for hazardous locations outlined in the Electrical Safety Code made under the Power Corporation Act.



Combustible liquid means any liquid having a **flash point** at or above 37.8°C and below 93.3°C.

Flammable liquid means a liquid having a **flash point** below 37.8°C and having a **vapour pressure** not more than 275.8 kPa (absolute) at 37.8°C as determined by ASTM D 323, "Vapor Pressure of Petroleum Products (Reid Method)".

Flash point means the minimum temperature at which a liquid within a container gives off vapour in sufficient concentration to form an ignitable mixture with air near the surface of the liquid.

5.13.5. Control of Fire Hazards

Flammable and combustible liquids

- 5.13.5.7.(1) The storage and handling of **flammable** and **combustible liquids** shall be in conformance with Part 4.
- (2) The total number of containers for **flammable** and **combustible liquids** in a dip tank area shall not exceed that required for 1 day's operations.

The Article applies to storage and handling of flammable or combustible liquids in dipping or coating processes involving flammable or combustible liquids in a manner that creates a fire or explosion hazard in buildings.

Sentence (1) is intended to state the application of Part 4.

Sentence (2) is intended to limit the fire load and reduce the risk of a fire spreading to other parts of the building, and endanger building occupants.

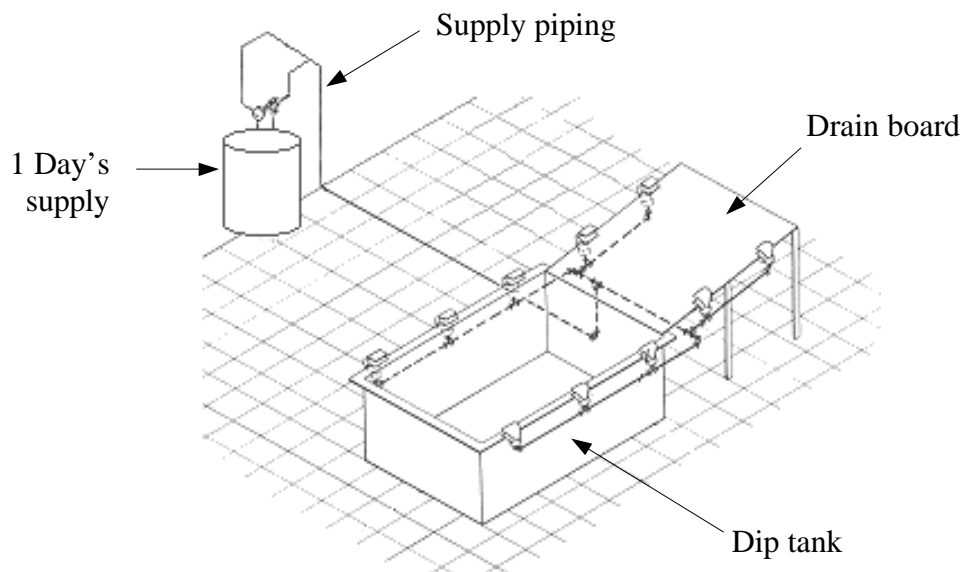

Combustible liquid means any liquid having a **flash point** at or above 37.8°C and below 93.3°C.
Flammable liquid means a liquid having a **flash point** below 37.8°C and having a **vapour pressure** not more than 275.8 kPa (absolute) at 37.8°C as determined by ASTM D 323, "Vapor Pressure of Petroleum Products (Reid Method)".

5.13.5. Control of Fire Hazards

Ignition sources

5.13.5.8. Smoking, open flames, spark producing devices and heated surfaces having a temperature sufficient to ignite vapours shall not be permitted in the vapour area of a dip tank.

The purpose of this Article is to eliminate potential ignition sources.

The article prohibits smoking, the presence of open flames, spark producing devices and heated surface having a temperature sufficient to ignite vapours in the vapour area of the dip tank.

The principle of segregating ignition sources to prevent fire is very important here as any of these sources of ignition can be the cause of a fire in a dipping area.

For example, ovens located directly above or adjacent to dipping and coating operations have been the ignition source for many fires. This equipment should be located as far as practical from dipping and coating operations.

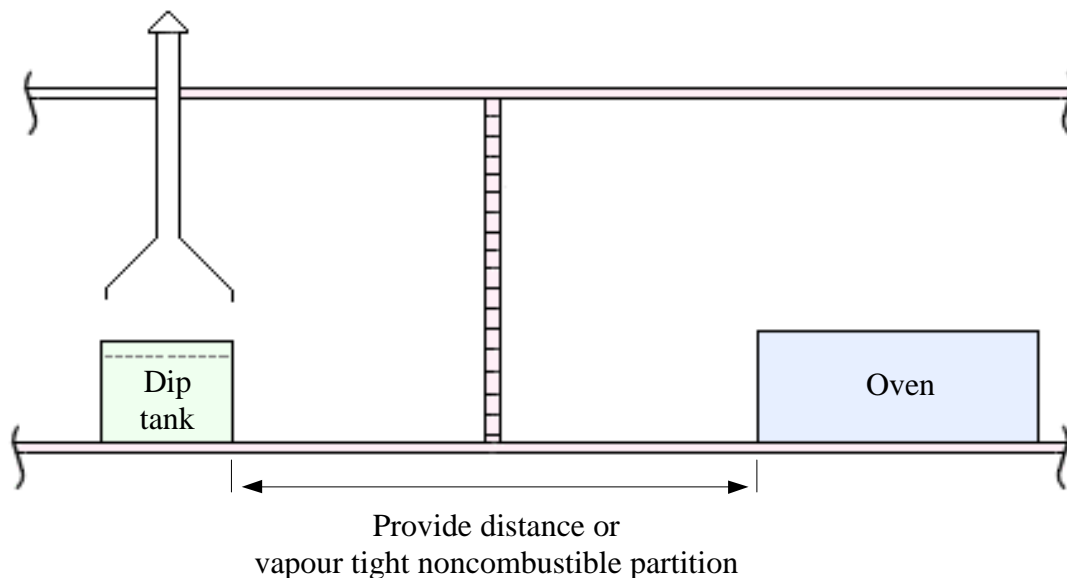

5.13.5. Control of Fire Hazards
Signs prohibiting smoking

5.13.5.9. Signs that prohibit smoking and that conform to Article 2.4.3.2. shall be posted conspicuously in the vicinity of dip tanks.

To state the application of Article 2.4.3.2.

Signs

2.4.3.2. The areas where smoking is not permitted shall be identified by signs having black lettering 50 mm high with a 12.5 mm stroke on a yellow background, except that symbols of 150 mm by 150 mm may be used in lieu of lettering, or covered by instructions established under a fire safety plan and available to all persons.

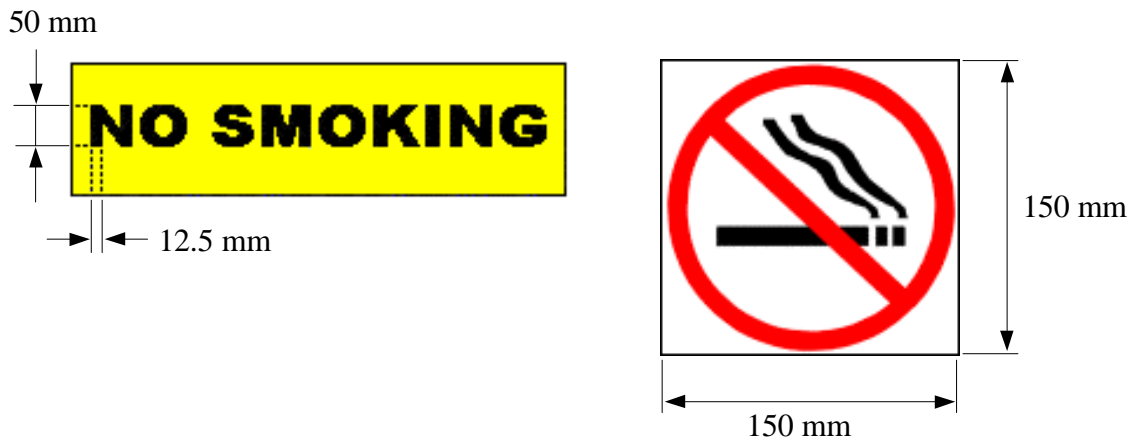

5.13.6. Fire Protection

Automatic sprinklers

- 5.13.6.1. Dip tanks shall be located only in rooms protected by an automatic sprinkler system installed in conformance with NFPA 13, “Installation for Sprinkler Systems”.

This Article requires that dip tanks, regardless of their size, be located only in rooms protected by an automatic sprinkler system installed in conformance with NFPA 13.

The sprinklers help to control the fire and prevent damage to the building.



5.13.6. Fire Protection

Tank covers and extinguishing systems

- 5.13.6.2.(1) Dip tanks with a capacity of over 550 L or over 1 m² liquid surface area shall be protected by
- (a) an automatic closing cover actuated by a device that also permits manual operation, or
 - (b) an **approved** automatic extinguishing system of a water spray, foam, carbon dioxide or dry chemical type.

The purpose of this Article is to prevent a fire in a dip tank spreading beyond the dip tank. Once a fire starts, quick extinguishment is important. This may be achieved by smothering the fire with a cover or automatic extinguishing system agent.

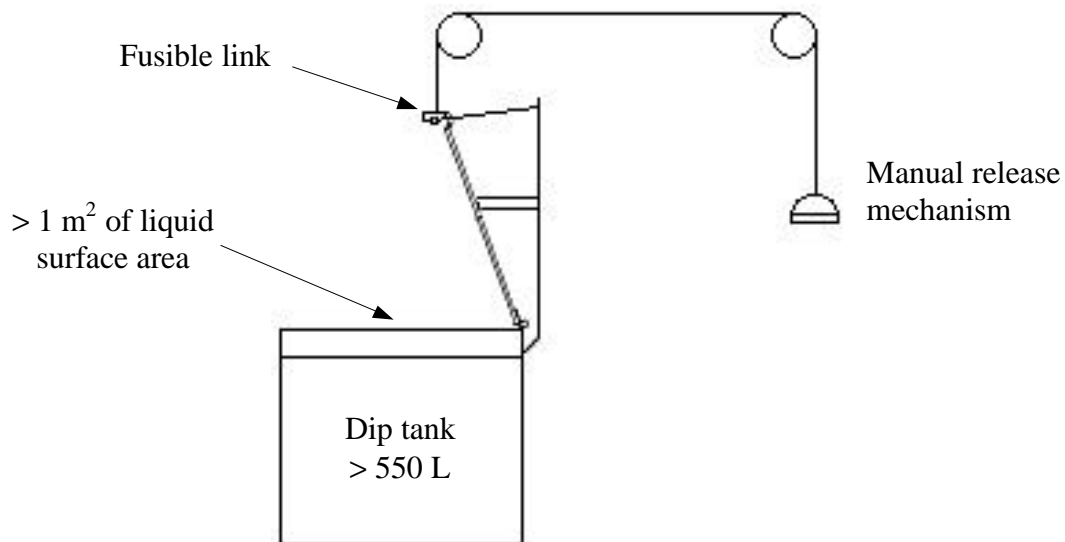

5.13.6. Fire Protection

Tank covers and extinguishing systems

- 5.13.6.3. Dip tanks containing either a **flammable** or **combustible liquid** with a **flash point** less than 43°C or a heated **combustible liquid** giving off flammable vapours shall conform to Article 5.13.6.2. when the capacity exceeds 45 L or when the liquid surface area exceeds 0.4 m².

This Article recognizes that smaller dip tank operations that produce vapours at ambient or operating temperatures require special fire protection features. By applying the requirements of Article 5.13.6.2., the objective is to quickly extinguish a fire that originates in the tank.

Combustible liquid means any liquid having a **flash point** at or above 37.8°C and below 93.3°C.

Flammable liquid means a liquid having a **flash point** below 37.8°C and having a **vapour pressure** not more than 275.8 kPa (absolute) at 37.8°C as determined by ASTM D 323, "Vapor Pressure of Petroleum Products (Reid Method)".

Flash point means the minimum temperature at which a liquid within a container gives off vapour in sufficient concentration to form an ignitable mixture with air near the surface of the liquid.

5.13.6. Fire Protection

Portable extinguishers

- 5.13.6.4. Areas in the vicinity of dip tanks shall be provided with portable extinguishers in conformance with Section 6.2.

This is a reminder to provide the areas in the vicinity of dip tanks, with manual fire extinguishers suitable for flammable and combustible liquid fires even though automatic fire extinguishing systems are in place.

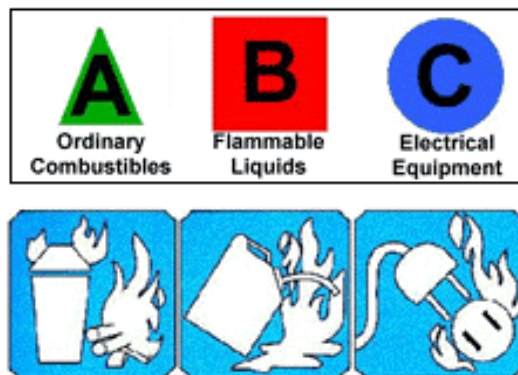

- Q1. Where must dip tanks involving flammable or combustible liquids where the quantity exceeds 45 L be located?
A1. Refer to Ontario Fire Code 5.13.1.1. and 5.13.1.2.
- Q2. How does the floor have to be constructed for a room where a dip tank is installed?
A2. Refer to Ontario Fire Code 5.13.2.1.
- Q3. What is the requirement for the liquid level in a dip tank?
A3. Refer to Ontario Fire Code 5.13.3.1.
- Q4. Where on the dip tank does the overflow pipe have to be installed?
A4. Refer to Ontario Fire Code 5.13.3.3.
- Q5. Where do the bottom drains discharge to?
A5. Refer to Ontario Fire Code 5.13.3.8.
- Q6. Can salvage tanks be used for permanent storage?
A6. Refer to Ontario Fire Code 5.13.4.1.
- Q7. Is smoking allowed in the vapour area of the dip tank?
A7. Refer to Ontario Fire Code 5.13.5.8.
- Q8. Does the room in which the dip tank is installed have to be sprinklered?
A8. Refer to Ontario Fire Code 5.13.6.1.
- Q9. Should a dip tank be equipped with an automatic closing cover, or an automatic extinguishing system?
A9. Refer to Ontario Fire Code 5.13.6.2.(1) and 5.13.6.3.
- Q10. Are fire extinguishers required in the vicinity of dip tanks?
A10. Refer to Ontario Fire Code 5.13.6.4.